

STUB END

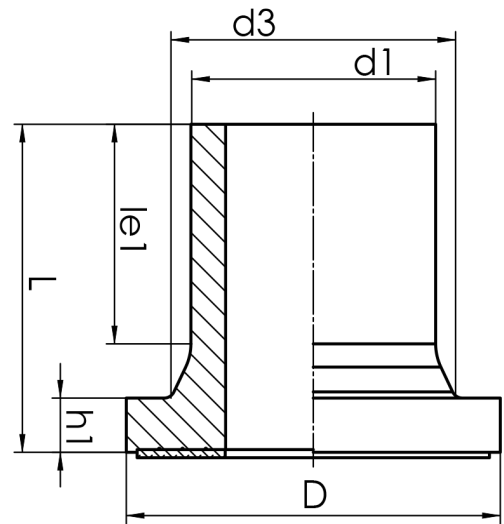

long spigot for butt- and electrofusion welding
 limited pressure load according to DVS 2210-1 Supplement 3 Part 2.1
 Design and dimensions according to ISO 9624 and DVS 2205 part 4
 suitable for loose flange DN150 PN25 according to DIN EN 1092-1

PE100



SDR 7,4



Art. No.	d1 [mm]	d3 [mm]	D [mm]	le1 [mm]	L [mm]	h1 [mm]	kg
4430040701800000	180	183	212	114	175	36	2,4

outer diameter maximized according to ISO 9624
 other materials and pressure classes on request
 supplied in a SET with an NBR gasket

For questions, please feel free to contact us at: Tel. + 49 281 98 414 - 0